



YZ23B SYNOPTOPHORE INSTRUCTION MANUAL

Preface

Thank you for your purchasing our YZ23B Synoptophore. Please read this manual carefully for the sake of your best use.

General Requirements for Safety

Please read carefully about the following precautions to avoid unexpected personal injury as well as the product being damaged and other possible dangers.

Precautions

1. Not to use this instrument in the environment where is prone to fire and to blast or where there is much dust and high temperature. Use it in the room and simultaneously be careful to keep it clean and dry.
2. Check that all the wires are correctly and firmly connected before use. Because that the instrument is well grounded.
3. Please pay attention to all the rating of the electrical connecting terminal.
4. Please only use the fuse according to the specifications and rated stipulated by our product.
5. Use the power cable supplied with this instrument.
6. Don't touch the surface of the lens and prism with hand or hard objects.
7. Turn off the main power first before replacing the main bulb and fuse.
8. To prevent the instrument from falling down to floor, it should be placed on the floor where the inclination angle is less than 10° .
9. Turn off the power and cover the instrument with dustproof cover when it is not in use.
10. In case there is any trouble, please first refer to the trouble-shooting guide. If it still can't work, please make contact with the authorized distributor or our After-Sales Service Department.

★ THE SAFETY MARKS USED IN THIS INSTRUMENT



ATTENTION **TERMINAL OF THE**
TYPE B PLEASE REFER TO THIS MANUAL PROTECTIVE GROUNDING

Contents

1.	Usage and Specification.....	4
1.1	Usage.....	4
1.2	Specification.....	4
2.	The Nomenclature of the Parts.....	6
3.	Assembly.....	9
3.1	Listing of accessories.....	9
3.2	Assembly Procedure.....	9
4.	Instruction.....	10
5.	Operation Procedure.....	13
5.1	Preparing before the Examination.....	13
5.2	Measuring the angle Kappa.....	14
5.3	Measuring of the subjective angle (e.g. the tiger and the cage slides, etc....)	14
5.4	Measuring the objective and retinal correspondence.....	14
5.5	Examining the fusion series functions (after the simultaneous perception series, e.g. a set of slides of one car with left wheels and another with right wheels, etc ...)	15
5.6	Examining the Stereoscopic Vision Series Functions (Qualitative Examination).....	15
5.7	Fusion series ability training.....	15
5.8	Abnormal retinal correspondence training.....	15
5.8.1	Treatment for the children.....	15
5.8.2	Flashing training.....	15
5.8.3	Watching training.....	15
5.8.4	After-image training.....	15
5.8.5	Haidinger’s Brush training.....	16
5.9	Stereoscopic vision training.....	16
5.10	Specs of the slides.....	16

6.	Maintenance.....	17
7.	Trouble Shooting Guide.....	18
8.	Responsibility.....	18
9.	Transportation and Storage.....	19

1. Usage and Specification

1.1 Usage

YZ23B Synoptophore integrates light, machine and electricity. It can examine, diagnose and treat the cockeye, amblyopia, diplopia and heterophoria of the patients by selecting different angle simultaneous perception series, fusion series, stereoscopic vision series and after-image slide. It can enhance the patients' sight. To those patients who need operations, it can be used to confirm the confines of the operations. It also can be used for the training for the function of the eyesight before or after the operations, and the probability of success will be improved.

YZ23B Synoptophore has half-transmitting mirrors in its optical system. The doctor can observe the actions of the patients' eyeball and the light reflecting by the cornea expediently.

There are not only Haidinger's Brushes but also red light ($\lambda = 640\text{nm}$) flashing device in this instrument for the convenience of treating paracentral fixation amblyopia.

Environment for use

- a) Temperature: $5^{\circ}\text{C}\sim 40^{\circ}\text{C}$.
- b) Relative humidity: $30\%\sim 80\%$.
- c) Atmospheric pressure: $700\text{hPa}\sim 1060\text{hPa}$.

1.2 Specification

1.2.1 Optics capability

Multiple 1.65x, the Field of Vision $\geq 56\text{mm}$.

1.2.2 Structure capability

The left and right eyepiece lens can rotate round the vertical axis: shut to 50° , disperse to 40° .

The left and right eyepiece lens can rotate round the horizontal axis: $\pm 30^{\circ}$.

The left and right eyepiece lens' slides can be 10Δ up and 10Δ down about the light axis.

The left and right eyepiece lens' slides can rotate round the light axis $\pm 20^{\circ}$.

The confines of the interpupillary distance adjusted: $45\sim 75\text{mm}$.

The confines of the forehead rest adjusted: 25mm up to down, 40mm front to back.

The confines of the chinrest adjusted: $75\sim 125\text{mm}$ distance of drawtube axis.

1.2.3 Electric capability

Input volt: 220V

Input frequency: 50Hz

Flashing device: manual and automatic

- The confines of automatic flashing frequency adjusted: 30~300 times/minute.
- The method of automatic flashing's light and shade alternate:
in a Cyc: 1/4 light 3/4 shade
1/2 light 1/2 shade
3/4 light 1/4 shade
- The type of the automatic flashing device:
Left and right light or shade simultaneously.
Left and right light or shade alternatively.
Left light and right shade for long, or contra.
Left shade and right shade or right for long, or contra.
- Light for darkroom: LED
- The slides、 After-Image and the Haidinger's Brushes are all illuminate by one group of LED. The brightness of the LED will adjust automatically on different purpose. The LED lighting has not only consistent chroma but also uniform illumination. Besides it has characteristics of low heat and long life.
- The brightness of the slide can be adjusted.
- The frequency of the Haidinger's Brushes can be adjusted: 50-100 revolution per minute.
- The specification of the fuse: 0.315A 250V(ϕ 5×20)

2. The Nomenclature of the Parts

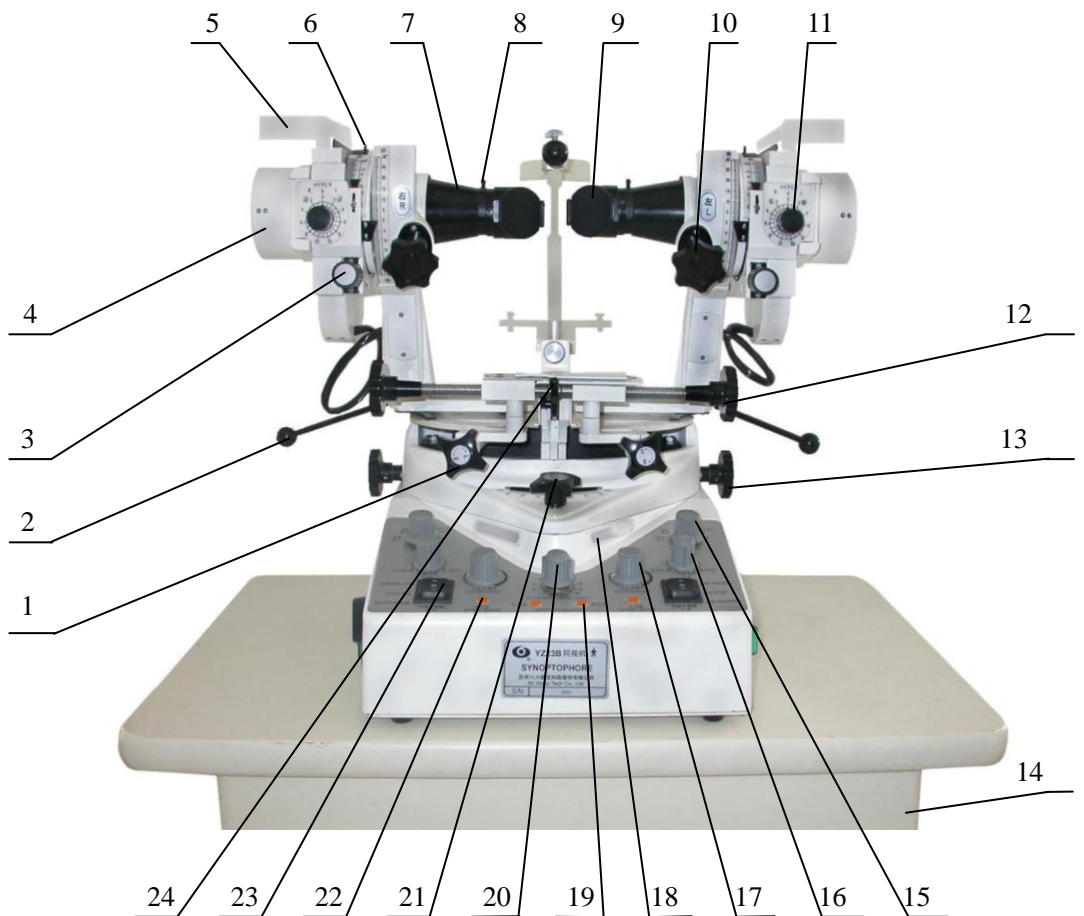

Fig.1 (Face)

- | | | |
|---|--|------------------------------------|
| 1. Tube locking controls (horizontal) | 9. Back cover of the eyepiece lens | 17. Light and dark phases controls |
| 2. Handles for adjustment of horizontal angle between tubes | 10. Revolving hand-wheel of the ocular canisters | 18. Light for darkroom |
| 3. Torsional deviation controls | 11. Vertical deviation controls. | 19. Flashing control knob |
| 4. Lamphouse cover | 12. Gather-radiation | 20. Flashing frequency |

- | | | |
|-----------------------------|---|--|
| 5. Haidinger's brush | handwheel
13. Interpupillary distance selection controls | knob
21. Chinrest height control |
| 6. Iris diaphragms | 14. Slides drawer | 22. On/off switches (after-image lamp) |
| 7. Eyepiece lens | 15. Pulse-width selector | 23. Reversing switches (Haidinger's brush) |
| 8. Red light flashing slice | 16. Speed control | 24. Central lock |

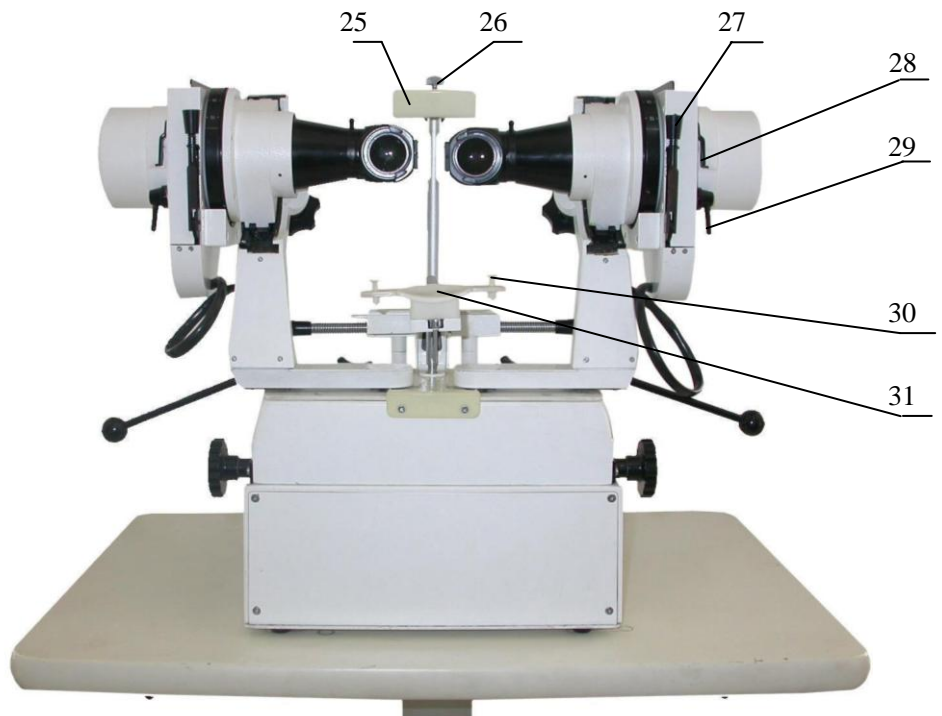

Fig.2 (Back)

- 25. Forehead rest
- 26. Binding bolt
- 27. Slides bouncing hole
- 28. Button of lamphouse cover
- 29. Dispersion patch controls
- 30. Pin
- 31. Chinrest

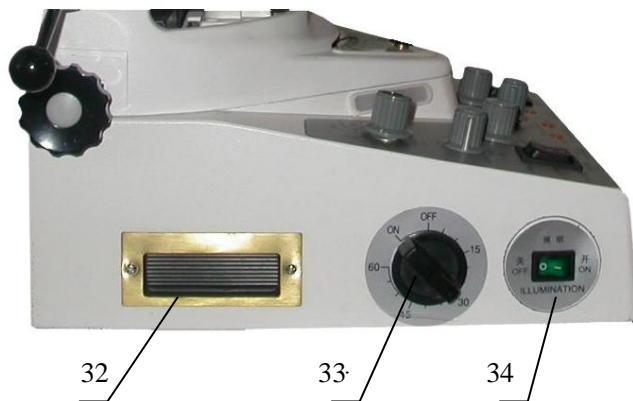

Fig.3 (Left)

- 32. Uplift hollowness
- 33. Timer switch
- 34. Light for darkroom switch

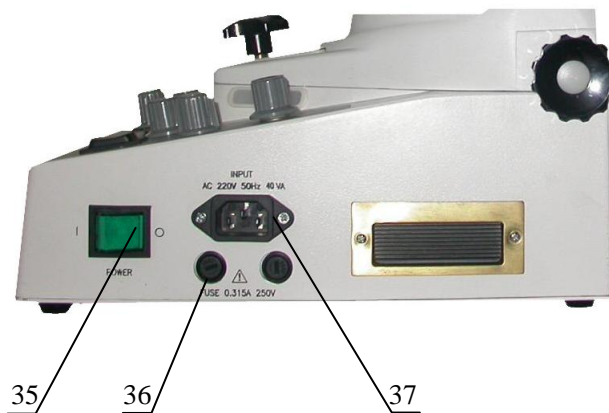

Fig.4 (Right)

35.Power supply switch

36.Fuse

37.Power supply plug

3. Assembly

Unpack tow transit boxes. Take out the dynamoelectric lift flat, synoptophore and accessories.



Attention: Please lift the synoptophore by the uplift hollownesses in the synoptophore's sides (32), not by the optical tubes.

3.1 Listing of accessories

3.1.1	Dynamoelectric lift flat	1pic
3.1.2	Table-board (with slides drawer)	1pic
3.1.3	Synoptophore (with one dust-proof cover)	1pic
3.1.4	Electrical wire of power supply	1pic
3.1.5	Slide-box (with 20 pairs Slides)	1pic
3.1.6	Color filter bag (with 2 red pieces and 1 blue piece)	1pic
3.1.7	Haidinger's Brush box (with two Haidinger's Brushes and one piece of cleaning-cloth in it)	1pic
3.1.8	500 pieces of Chinrest Mat-paper	
3.1.9	I type of screwdriver with plastic handle (75×3)	1pic
3.1.10	Single head solid wrench (gap width 14)	1pic
3.1.11	Fuse-box $\Phi 5 \times 20$ (0.315A, 250V)	2pics
3.1.12	Illuminant	1pic

3.2 Assembly procedure

3.2.1 Fixing the working-table-board

Please screw off the four M8×20mm hexagon bolts with spring gasket in the armor plate in reverse of working-table-board by the spanner. Then zero the screws in working-table-board on the assembly holes in the dynamoelectric lift-flat columniation. Finally screw down the bolts and the spring gaskets by spanner (indicated in Fig.5).

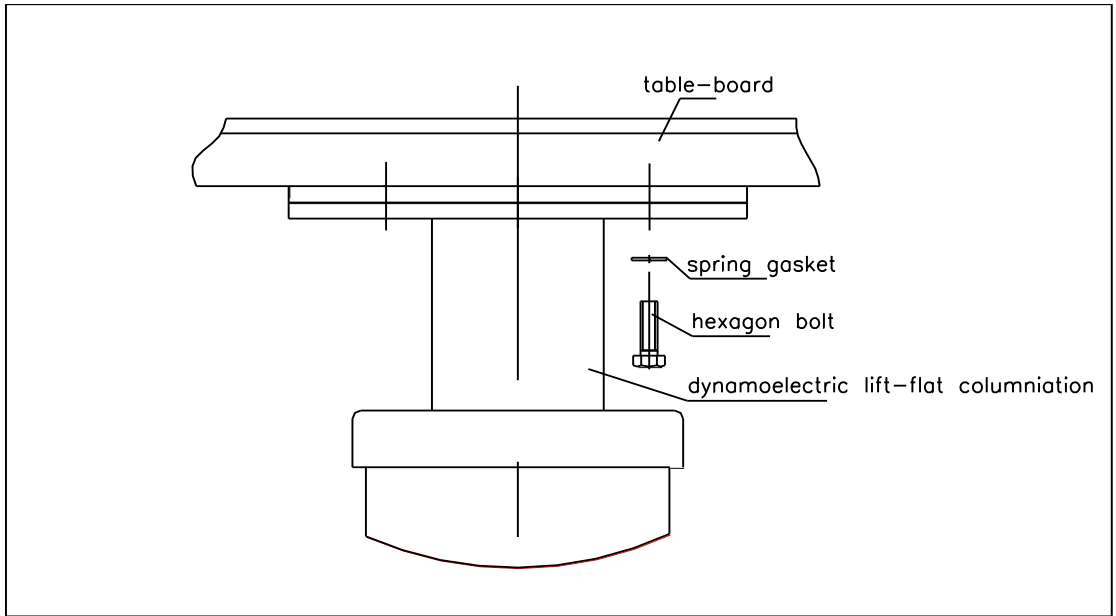

Fig.5

3.2.2 Assembly of the whole instrument

Put the synoptophore on the table-board of the dynamoelectric lift flat. The front of the synoptophore (the operation faceplate) and the front of the dynamoelectric lift flat (the switches of the lift control faceplate) are at one side.

Turn on the brake-switch truckle while forcing the dynamoelectric lift flat. Brake it after it reach the working-point.

4 Instruction

4.1 Connection to electricity supply

A three-line-cable is supplied with the instrument. One port is plugged into the Power supply plug (37) in the synoptophore's side, and the other one is plugged into the bottom side of the dynamoelectric lift flat. The one which the dynamoelectric lift flat provided with is plugged into the electrical outlet.



Attention: Please use the special power supply wires of this instrument. Ensure the instrument is earthed well.

4.2 Turn off the power supply

When the switch of the power supply (35) is at "I", the power supply lamp is light. It means the power supply is switched on. When the switch is at "O", it means the power supply is off. When the instrument is working well, the Timer switch is at "ON", according to the following 4.3. The switch should be at "O" before the connecting between the three line cable and the electrical outlet.

4.3 Timer device

The switch of the power supply (35) is at "I", and the timer switch (33) to "ON" anti-clockwise when timing is not needed. Turn the switch to "O" when switching off

the instrument.

The switch of the power supply (35) is at “I”, and rotate the timer switch (33) to the needed time clockwise when timing is needed. The timer switch will automatically go to “OFF” and shut down on time. The instrument will end the working.



Attention: Do turn the switch to the “O” while ending the working.

4.4 Set the chinrest padding-paper

Pull out the two pins (30) and place 50~80 pieces of chinrest padding-paper on the chinrest. Insert the pins after all the holes are zeroed in. Take down one piece of the padding-paper when the last patient’s operation is finished and the next patient’s operation is ready.

4.5 Adjustment of the chinrest

Rotate the chinrest height control (21) to adjust the vertical position. Loosen the tightening-bolts of the chinrest to adjust the position of fore-back. It can make the patient’s sight line concurrent with the eyepieces’ centre.

4.6 Adjustment of the forehead rest

Loosen the tight-bolts in the underside of the forehead rest pole to adjust the vertical position of the forehead rest. Loosen the Binding bolt (26) in the upside of the chinrest pole to adjust the fore-back position of the forehead rest. It keeps the distance around 10~15mm between the patient’s eyes and the eyepieces.

4.7 Adjustment of the interpupillary distance

Rotate the interpupillary distance selection controls (13) to make the light-axis distance between the left eyepiece and the right eyepiece to be equal to the patient’s interpupillary distance. Then the numerical value of the interpupillary distance can be read from the interpupillary distance scale.

4.8 Adjustment the position of the left and right eyepieces

Loosen the tube locking controls (horizontal) (1), and pull the handles for adjustment of horizontal angle between tubes (2). The left and right eyepieces can close or open separately. The numerical data can be read from the left and right scales.

Lock the tube locking controls (horizontal) (1) and pull the central lock (24) up, so that the central lock can lock the screw. Rotate the Gather-radiation handwheel (12), so that the left and right eyepieces can close and open synchronously. The numerical data can be read from the scales.

Lock the tube locking controls (horizontal) (1) and pull the central lock (24) down. Pull the handles for adjustment of horizontal angle between tubes (2) fore or back, so that the left and right eyepieces can move to the same direction synchronously.

Rotate the Revolving hand-wheel of the ocular canisters (10),so that the left and the right eyepieces can rotate round the transverse axis. The numerical data of the angle can be read from the elevation and depression scales.

4.9 Adjustment of the slides’ position

Rotate the vertical deviation controls (11), so that the slides can move relative to the eyepieces. The angle of view can be read from the vertical deviation scales (prism degree).

Rotate the torsional deviation controls (3), so that the slides can rotate round the eyepieces' light-axis. The angle can be read from the lamp-box scales.

Press the slides' bouncing hole (27) and take out the slides. According to the demand, the slides can also bounce.

4.10 Light for darkroom

Press the light for darkroom switch (34), so that the light for darkroom (18) can be on in order to observe and operate the panel.

4.11 Adjustment the brightness of the slide light

Rotate the light and dark phases controls (17), so that the brightness of the slides can be adjusted the fitting lightness.



Attention: When you want to change the illumination mode from after-image or Haidinger's brush lighting to slides lighting, you must first switch the On/off switches (after-image lamp) (22) in order to turn off the after-image or Haidinger's brush lighting.

4.12 Flashing device

There are all together two types of flashing device, one is manual and the other is automatic

4.12.1 Manual flashing

Rotate the two Pulse-width selectors (15) to on or off (on means turning on generally, and off means turning off usually). Put your two fingers on the Flashing control knobs (19). The lamp will be light once or dark once for once press.

4.12.2 Automatic flashing

Rotate the two Pulse-width selectors (15) to "1/4"~ "3/4", then the system come into automatic flashing state.

(a) Meanings of Pulse-width selector's pointing

Rotate the two Pulse-width selectors (15) to "1/4", then the left and the right lamp flash synchronously. In a Cyc, 1/4 Cyc is light, 3/4 Cyc is dark.

Rotate the two Pulse-width selectors (15) to "3/4", then the left and the right lamp flash synchronously. In a Cyc, 3/4 Cyc is light, 1/4 Cyc is dark.

Rotate the two Pulse-width selectors (15) to "1/2 same", then the left and the right lamp flash synchronously. In a Cyc, 1/2 Cyc is light, 1/2 Cyc is dark.

Rotate the two Pulse-width selectors (15) to "1/2 alternate", then the left and the right lamp flash synchronously. In a Cyc, 1/2 Cyc one is light the other is dark, 1/2 Cyc one is dark the other is light.

Rotate one Pulse-width selector to "1/4" or "3/4", the other to "3/4" or "1/4". In a Cyc, one lamp is light in 1/4 Cyc or in 3/4 Cyc, and is dark in 3/4 Cyc or in 1/4 Cyc. The other lamp is contrary.

(b) Adjustment the frequency of the automatic flashing

Rotate the Flashing frequency knob (20), so that the frequency of the automatic flashing is divided into ten levels, from slowness to rapidity. The frequency of each level is as follows.

1—30Times/minute 2—60Times/minute 3—90Times/minute 4—120Times/minute
5—150Times/minute 6—180Times/minute 7—210Times/minute 8—240Times/minute
9—270Times/minute 10—300Times/minute

4.13 Adjustment of the veer and the rotate speed of the Haidinger’s Brush

Take the two Haidinger’s Brushes from the packing case. Insert them into the slide boxes’ cavum. Turn the reversing switches (23) of Haidinger’s Brush. Observe whether the veer is changed through the eyepieces. Rotate the speed controls of the Haidinger’s Brush (16), so that the speed of the brush-shape whirlabout can be adjusted.

4.14 Adjustment the Iris diaphragms

Rotate the Iris diaphragms (6) slowly while treating the amblyopia with the Haidinger’s Brush. The diaphragms’ diameter can be adjusted arbitrarily in a certain scope.

4.15 Fix the dispersion patch controls

The on/off switches (after-image lamp)(22) should be turned on while using Haidinger’s Brush. At the same time, rotate the dispersion patch controls up, so that the dispersion can be in the rays. Then the “brush” will be viewable.

In order to get better illumination, turn on the after-image lamp while doing the after-image training. At the same time, rotate the dispersion patch’s handle down, so that the dispersion patch can exit the light-way.

The same method should be followed when slides light is used.

4.16 Red light flashing device

Rotate the dustproof-ring round eyepiece lens (7) 180 degrees, so that the up notch will basset. Insert the two red color filter pieces (8) in it, then rotate the pulse-width selector (15) to any station between 1/2~3/4 and the flashing frequency knob (20) to 2~4 level (flashing 60~120times/minute). Finally adjust the lightness of the light and then the flashing red light can be seen in eyepieces.

1-2 times/day, 10 minutes each time. One month is one period of treatment until the vision is developed. (Only the reference. Material treatment is decided by doctor.)

Draw the red color filter pieces out and place it into slides drawer (14) and rotate the dustproof-ring back when not using.

5 Operation Procedure

5.1 Preparing before the examination

5.1.1 Connect power supply and set the power supply switch to “I”. Rotate the timer knob to “ON” anti-clockwise. Rotate the selector switch to off. Adjust the brightness of the light mezzo.

5.1.2 Set all the pointers of dial at zero.

5.1.3 Let the patient sit in the work chair. Set his chin on the chinrest. Set his forehead abut on the forehead rest. Adjust the height of the lift flat and the chinrest, so that the centre of the patient's eyes is at the same horizon with the light-axis of the eyepieces.

5.1.4 Adjust the interpupillary distance selection controls, and make the light-axis distance between the left eyepiece and the right eyepiece equal to the patient's interpupillary distance. Then the numerical data of the interpupillary distance can be read from the interpupillary distance scale.

5.1.5 Open the elliptic back cover of the eyepiece lens (9) at 45 degrees and look into directly through the half-transmitting mirrors when doctors want to observe the actions of the patients' eyeballs and the light reflecting by the cornea. Close the cover with that when no using.

5.2 Measuring the angle Kappa

There is a row of small square grid on the slide which measuring the angle kappa. In each grid there is letters, numbers or images. The angle of every two near grids is 1 degree. "0" is in the center of the grids.

Place the slide in the slide boxes and instruct the patient to look at the zero mark with simple eye. The doctor press the synoptophore's flashing button, and observe the reflection of the light on the patient's cornea. The kappa angle will be positive when nasal lean, and negative when temporal lean if the reflected light is not in the centre of the pupil. Then the patient should be instructed to look at successive numbers, or letters, until the reflection is in the centre. Numerate the kappa angle by which is looking at. The same procedure should be carried out with the other eye.

5.3 Measuring of the subjective strabismic angle (e.g. the tiger and the cage slides)

Place a set of simultaneous perception series slides in the slide boxes. The cage slides is in front of the regardant eye and the tiger slide is in front of the suffering eye. Lock the lens arm in front of the regardant eye at the zero. Let the patient move the handles for adjustment of horizontal angle between tubes fore or back by the side of his suffering eye till the tiger enter into the cage. Then the scale value by the side of the suffering eye is the subjective strabismic angle.

5.4 Measuring the objective strabismic angle and retinal correspondence

Light and extinguish the left and right optical tubes' lamp alternately and lock the arm by the side of the watching eye at zero after measuring the subjective angle. Observe any eye-position movement to take place. If no movement, the objective angle corresponds to the subjective angle, and it is normal retinal correspondence. If there is any movement, the patient should move the optical tube by the side of the suffering eye or adjust the slide vertical deviation handle until the reflection of the light is in the centre of the pupil. The scale value by the side of the suffering eye is the objective angle if the eye-position doesn't move when the bulbs is extinguished alternately. If the objective angle doesn't correspond to the subjective angle, it is the abnormal retinal

correspondence and the margin of the two angles is the abnormal angle. Then the examination is repeated with the other eye.

5.5 Examining the fusion series functions (after the simultaneous perception series, e.g. a set of slides of one car with front-wheel and another with rear wheel)

5.5.1 Place the slides in the slide boxes, and let the patient observe the slides. Move the handles for adjustment of horizontal angle between tubes fore or back at the same time, so that the two images can inosculate to be an integrated image that means an integrated car with front-wheel and rear wheel. If the images can't inosculate to be an integrated image, then choose the larger angle fusion slides.

5.5.2 After the images inosculating and the optical tubes' arms being locked, open and close separately, till the two images are detached to a small extent. The open and close angles' summation at the two sides' scales shows the fusion series ability.

5.5.3 Third dimension will come into being while observing the fusion series slides expect for the above two functions.

5.6 Examining the stereoscopic vision series functions (qualitative examination)

Use the tailor-made stereoscopic vision slides for observing. If the patient can perceive the third dimension, he is provided with a certain extent stereoscopic vision. (It's qualitative testing.)

Our company has manufactured a suit of stochastic dots slides by what we can quantificationally measure the visual- acutance (40'' -1000'') of the stereoscopic vision series functions. (For choose and buy)

5.7 Fusion series ability training

The doctor places the lens arms at the fusion point, and lock the two lens arms. Then do the open and close movement.

5.8 Abnormal retinal correspondence training

5.8.1 Treatment for the children: Because of their little age, their discretion is infirm. Select the larger simultaneous perception series images. Place the slides in the slide boxes and lock the lens arms. The doctor makes the other lens arm out and in, so that the two images is crossed at the objective angle from far to near, and the superposition will keep a period of time.

5.8.2 Flashing training: Use the smallest concave simultaneous perception series images in the yellow spot centre. Place the optical tubes in the objective angle. Light and extinguish the two optical tubes alternately with the automatic device. The two images will overlap at the objective angle when the lighting lights in front of the eyes from slowness to rapidity.

5.8.3 Watching training: The simultaneous perception series images are used. Place the optical tubes in the objective angle. One eye of the patient watches at the cage, the other watches at the tiger. Move the lens arms, so that the tiger go forward or back off to pass through the cage. Do this training time after time, and it will be normal retinal correspondence.

5.8.4 After-image training: Place the after-image slides in the two slide boxes. Turn

on the special after-image lamps and flash them alternately to form the after-image. Then the patient should watch at the after-image continuously. After seeing the integrated cross from the horizontal and vertical lines, insert the simultaneous perception series image, so that the two images will overlap.

5.8.5 Haidinger’s Brush training: Take out the slides and insert the accessories of the Haidinger’s Brush. First, let the patient learn to observe the “light brush” phenomena. The patient will see the phenomena as long as he fixes attention on it and watch some point on the blue glass with one eye. The color of the “light brush” is blue-purple which is darker than the color of the background. It will circumrotate slowly and its rotary speed can be adjusted in a stated bound. The rotary “light brush” is used to stimulate the central concave’s restrainability to activation the cone cells.

After the patient has the ability of watching “light brush”, Reduce the iris diaphragm gradually. This can constrain the patient transfer from paracentral fixation to central fixation gradually. When patient can see “light brush” in an area about 10mm diameter, doctor can insert the airplane -image slide. Tell patient looking the “light brush” as the airscrew of airplane in order to improve the interest and consolidate the curative effect.

When simple eye is training, insert the blue color filter into the other drawtube’s notch. Blue light can be seen with double eyes.

5.9 Stereoscopic vision training

Observe the tailor-made stereoscopic slides again and again to solidify and advance the treatment effect of cockeye and amblyopia. And it also gathers ahead the third dimension ability.

5.10 Specs of the slides:

Name	Number	Design (Control)	Horizontal Angle	Vertical Angle
Simultaneous Perception Series Slides	T1/T2	Tiger/Cage	10° /13°	7.5° /9°
	T3/T4	Mouse/Light	6.8° /10.8°	7° /11.2°
	T5/T6	Frog/Lotus Leaf	4° /7°	4° /4°
	T7/T8	Mouse/Ladder	1.2° /2.5°	4.5° /11°
	T9/T10	Rectangle/Triangle/Circle	7° /1.7° /4.3°	7° /1.5° /4.3°
Fusion Series Slides	R1/R2	Kitty (Cravat and Tail)	9°	12°
	R3/R4	Monkey (Ant and Fungus)	8°	10°
	R5/R6	Robot Cat (Right Hand and Left Hand)	7°	8°
	R7/R8	Zebra (Left Feet and Right Feet)	6°	6°

	R9/R10	Car (Frontal Wheel and Back Wheel)	3°	0.7°
Stereoscopic Vision Series Slides	L1/L2	Magus	10°	9.5°
	L3/L4	Four Balls	14°	3.8°
	L5/L6	Chimney	5.4°	5.4°
	L7/L8	Fauna	15.4°	18.4°
	L9/L10	Stochastic Spot 1 (fig. "12")	17°	17°
	L11/L12	Stochastic Spot 2 (fish)	17°	17°
Angle k Slides	K1/K2	Animal and Letter	1°	13°
After-image Slides	H1/H2	Transverse Line and Horrent line		
Training Slides	S1/S1	Small Airplane/ Homocentric Round		
Cross slide	S3/S4	Reticle with scale		

Attention:

(1) Pay attention to the left and the right position when the **L9, L10, L11, L12** slides are inserted into the slide boxes. (According to the patients' circs.)

(2) Insert the bolt at the back of the slides drawer when you want to lock the drawer.

6 Maintenance

6.1 Before leaving the factory, the instrument has been well adjusted. Be careful to maintain it and do not disassemble it optionally before you are familiar with its inner structure and capability. Insure the instrument against depress the capability of the instrument.

6.2 Be careful to protect the instrument from damp, dust and corrosive gas. The environment temperature should be 5°C to 40°C, the relative humidity 30% to 80% and the atmospheric pressure 700hPa to 1060hPa.

6.3 When it is not in use, set all the pointers at zero.

6.4 Keep the instrument clean and the surface can be cleaned by the waterish cloth. Do not use the cleanser which contains cauterant to protect the paint of the surface from dissolved. If there is any dust on the surface of the optic lens and the slides, blow it with the blowing balloon, or whisk it with the horsetail whisk brush. If there is any oil smear on the surface of the optic lens, wipe off it duly with the absorbent cotton dipping the 85% aether and 15% alcohol mixed liquid. When it is not in use, it should

be covered by the mantle.

6.5 When the Haidinger’s Brush is not in use, it should be conserved in the appropriate case.

6.6 When the light doesn’t work, shut off the power first, then open the lamphouse cover (4) by screw off the two bolts on the surface with small screwdriver. Take out the bad light and pull out the power plug. Remove the two stanchions to the new light and plug into the power plug. Place it into the lamphouse in the end.

6.7 After fusion, bear out the cause for it and screw off the fuse box cap with a screwdriver. Then replace the same specs new fuse with the same specifications.

6.8 Replace the patient, and rip off the chinrest padding-paper. The forehead rest should be cleaned with the disinfectant liquid too.

7 Trouble Shooting Guide

In case there is any trouble, please check according to the following table for reference. If it still cannot work, please contact the After-Sales Service department of 66 VISION-TECH CO., LTD. or an authorized distributor.

Trouble	Possible cause	Remedy
The bulb is not on	The power supply wire is not connected with the electrical outlet.	Look over the plug and the outlet.
	The switch of the power supply is on “O” or the switch of the clock is on “OFF”.	Set the switch of the power supply is to “I” and the switch of the clock is to “on”.
	The light is burnt out.	Replace the new light.
	The fuse is melt.	Replace the compatible fuse.
The Haidinger’s Brush does not circumgyrate	The electrical plug of the Haidinger’s Brush does not plug into the inner jack well.	Plug it into the jack again.
The iris diaphragm is locked	The diaphragm deviates or the cover shifts.	To be repaired by professional of our company or filiale.

8 Responsibility

If there is any need for inquiry of relative information, service or any questions, please contact with us directly or our authorized distributors.

9 Transportation and Storage

9.1 Before leaving the factory, the instrument has been well adjusted, don't disassemble it anyway.

9.2 During the transportation, be careful to protect it from wetness, upside down and violent vibration.

9.3 This instrument should be stored in a well ventilated room without corrosive gas where the relative humidity should be 10%~80% and environment temperature should be $-40^{\circ}\text{C}\sim 40^{\circ}\text{C}$.

★ **We will not notice you otherwise if the design, specification or the slide's content are changed.**

